**DESCRIPTION:**

YKM-DD : Double deflection supply circular duct grilles, with adjustable horizontal and vertical blades, inclined hit and miss damper and circular shaped frame.

YKM-DT : Single deflection Return Grilles, with adjustable horizontal or vertical blades and circular shaped frame.

MATERIAL :

Specially extruded from 6063 aluminium profile.

FUNCTION :

It is used as air extraction grille in air ventilation systems.

FINISHING :

- Standard colours are RAL 9010 and RAL 9016
- Other colours are available with enamel paint.

INSTALLATION :

- System with screws is standard.
- No fixing.

ACCESSORIES:

- If desired, it is possible to add a damper to adjust the amount of air to be collected.

PKD: Parallel Blade Damper

ZKD: Opposite Blade Damper

HKD: inclined Blade hit Damper



STANDARD SIZES :

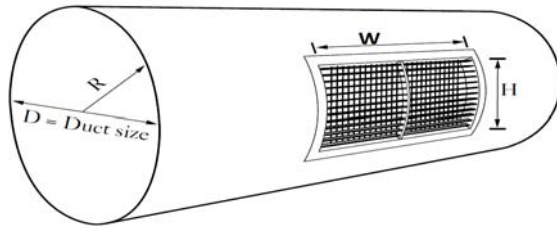

W : 325 – 425 – 525 – 625 – 825 – 1025 - 1225mm

H : 75 – 125 – 175 - 225m

* Any combination of these sizes

YKM																				
Width																				
Height	10"	12"	14"	16"	18"	20"	22"	24"	26"	28"	30"	32"	34"	36"	38"	40"	42"	44"	46"	48"
3"	X	X	X	X	X	X	X	X	X	X	X	X	X	X	X	X	X	X	X	X
4"	X	X	X	X	X	X	X	X	X	X	X	X	X	X	X	X	X	X	X	X
6"	X	X	X	X	X	X	X	X	X	X	X	X	X	X	X	X	X	X	X	X
8"			X	X	X	X	X	X	X	X	X	X	X	X	X	X	X	X	X	X
10"				X	X	X	X	X	X	X	X	X	X	X	X	X	X	X	X	X
12"					X	X	X	X	X	X	X	X	X	X	X	X	X	X	X	X

FRAME TYPES :

YKM-TM FRAMES:

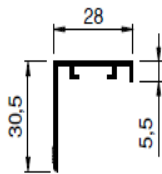

28mm Frame

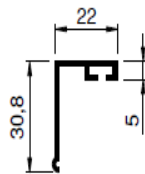

22mm Frame

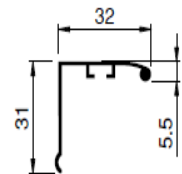

32mm Frame

YKM-DM FRAMES:

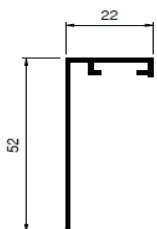

22mm Frame

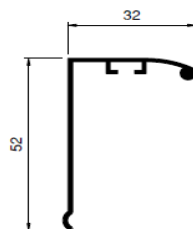

32mm Frame

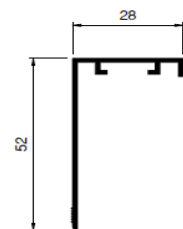

28mm Frame

DRAWINGS :

YKM-D CIRCULAR FRAME:

YKM-TD TYPE WITHOUT DAMPER

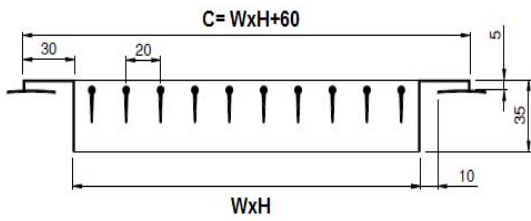

YKM-DD TYPE WITHOUT DAMPER

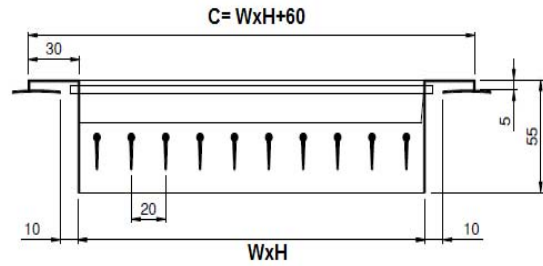

YKM-TD TYPE INCLINED HIT WITH DAMPER

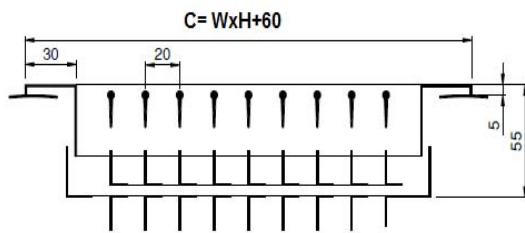

YKM-DD TYPE INCLINED HIT WITH DAMPER

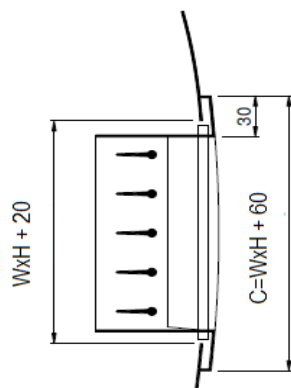
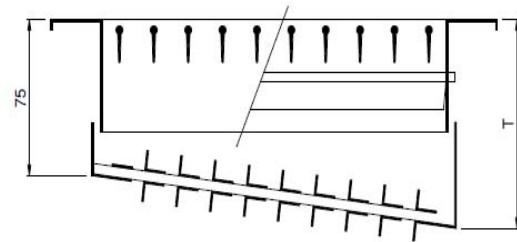

YKM-D



YKM-SUPPLY SELECTION TABLE:

Flow Rate m ³ /h	W X H	425 X 75	525 X 75	625 X 75	425 X 125	525 X 125	625 X 125	425 X 225	525 X 225	625 X 225	825 X 225	1025 X 225
					825x75	1025x75	1225x75	525x175	625x175	825x175	1025x175	1225x75
100	A (m ²)	0,015	0,019	0,023	0,030	0,037	0,045	0,060	0,075	0,090	0,120	0,150
	Lt (m)	2,4										
	NR											
	Pt (Pa)	8										
	Vk (m/s)	1,9										
150	Lt (m)	3,6	3,2									
	NR	20	15									
	Pt (Pa)	19	12									
	Vk (m/s)	2,8	2,2									
	Lt (m)	4,7	4,2	3,8								
200	NR	28	23	18								
	Pt (Pa)	33	21	14								
	Vk (m/s)	3,7	2,9	2,4								
	Lt (m)	7,1	6,3	5,7	5,0	4,5						
	NR	38	33	29	23	19						
300	Pt (Pa)	75	47	32	19	15						
	Vk (m/s)	5,5	4,4	3,6	2,8	2,2						
	Lt (m)	9,5	8,4	7,6	6,7	6,0	5,5					
	NR	46	41	37	31	26	22					
	Pt (Pa)	134	83	47	33	22	15					
400	Vk (m/s)	7,4	5,8	4,8	3,7	3,0	2,5					
	Lt (m)		15,0	11,0	10,0	9,0	8,2	7,1	6,4			
	NR		55	47	41	37	32	26	21			
	Pt (Pa)		200	128	75	49	33	19	12			
	Vk (m/s)		9,0	7,2	5,1	4,5	3,7	2,8	2,2			
600	Lt (m)					12,0	11,0	9,5	8,5	8,6		
	NR					44	40	34	29	26		
	Pt (Pa)					88	59	33	22	15		
	Vk (m/s)					6,0	4,9	3,7	3,0	2,5		
	Lt (m)						14,0	13,0	13,0	11,0	10,0	
800	NR						44	39	36	29	25	
	Pt (Pa)						75	47	35	20	13	
	Vk (m/s)						5,5	4,4	3,7	2,8	2,3	
	Lt (m)								21,0	20,0	17,0	15,0
	NR								50	46	40	35
1200	Pt (Pa)								118,0	80,0	42,0	28,0
	Vk (m/s)								7,0	5,8	4,2	3,3
	Lt (m)										27,0	21,0
	NR										55	43
	Pt (Pa)										155,0	50,0
1800	Vk (m/s)										7,8	4,5
	Lt (m)											10,0
	NR											52
	Pt (Pa)											105,0
	Vk (m/s)											6,5

SELECTION CRITERIA

Ceiling Height
H = 3+- 0,5 mm
Vt = 0,25 m/s
Damper %100 open



YKM-RETURN SELECTION TABLE :

Flow Rate (m ³ /h)	w X H	425 X 75	525 X 75	625 X 75	425 X 125	525 X 125	625 X 125	425 X 225	525 X 225	625 X 225	825 X 225	1025 X 225
					825x75	1025x75	1225x75	525x175	625x175	825x175	1025x175	1225x75
	A (m ²)	0,019	0,023	0,028	0,037	0,046	0,055	0,074	0,092	0,110	0,138	0,166
150	NR	-										
	Pt (Pa)	21										
	Vk (m/s)	2,3										
200	NR	-	-									
	Pt (Pa)	18	12									
	Vk (m/s)	3,0	2,5									
300	NR	28	25	20	-	-						
	Pt (Pa)	40	30	18	12	6						
	Vk (m/s)	4,8	3,8	3,0	2,3	1,8						
400	NR		31	32	22	-	-					
	Pt (Pa)		49	27	18	12	8					
	Vk (m/s)		5,0	4,0	3,0	2,5	2,0					
600	NR				32	26	23	-	-			
	Pt (Pa)				45	25	18	10	5			
	Vk (m/s)				4,9	3,6	3,0	2,3	1,8			
800	NR					34	30	24	20	-		
	Pt (Pa)					49	32	18	12	8		
	Vk (m/s)					5,0	4,0	3,0	2,5	2,0		
1200	NR							34	29	23	22	
	Pt (Pa)							42	24	18	10	
	Vk (m/s)							4,6	3,5	3,0	2,4	
1800	NR									36	32	27
	Pt (Pa)									37	27	18
	Vk (m/s)									4,2	3,7	3,0
2500	NR										40	35
	Pt (Pa)										49	31
	Vk (m/s)										5,0	4,0

SELECTION CRITERIA

Ceiling Height
H = 3+- 0,5 mm
Vt = 0,25 m/s
Damper %100 open



MAXIMUM HEIGHT MEASUREMENTS ACCORDING TO THE DIRECTIONS:

	Round Duct Diameter (mm)										
∅ (mm)	200	250	300	350	400	450	500	550	600	900	1200
Hmax.(mm)	75	75	100	100	125	125	150	150	150	200	250

ROUND DUCT DIAMETER YKM SELECTION TABLE:

W x H	DIAMETER
225 x 75	150
325	
425	
525	
625	
825	
1025	
1225	
225 x 125	300
325	
425	
525	
625	
825	
1025	
1225	
325 x 225	600
425	
525	
625	
825	
1025	
1225	



ROUND DUCT GRILLES SELECTION:

YKM-D EFFECTIVE AREA Ak (m2) :

H (mm)	Ak (m ²)						
	W (mm)						
	325	425	525	625	825	1025	1225
75	0,011	0,015	0,019	0,023	0,030	0,037	0,045
125	0,023	0,030	0,037	0,045	0,060	0,075	0,090
175	0,034	0,045	0,056	0,068	0,090	0,113	0,135
225	0,045	0,060	0,075	0,090	0,120	0,150	0,180

Table-1

YKM-T EFFECTIVE AREA Ak (m2) :

H (mm)	Ak (m ²)								
	W (mm)								
	200	250	300	400	500	600	800	1000	1200
100	0,017	0,021	0,025	0,034	0,042	0,049	0,066	0,082	0,098
150	0,025	0,031	0,037	0,049	0,061	0,074	0,099	0,123	0,147
200	0,034	0,042	0,049	0,066	0,082	0,098	0,132	0,164	0,196
300			0,073	0,098	0,123	0,147	0,198	0,246	0,294
400				0,131	0,164	0,196	0,264	0,328	0,392
500					0,205	0,245	0,330	0,410	0,490

Table-2



SUPPLY ROUND DUCT GRILLE:

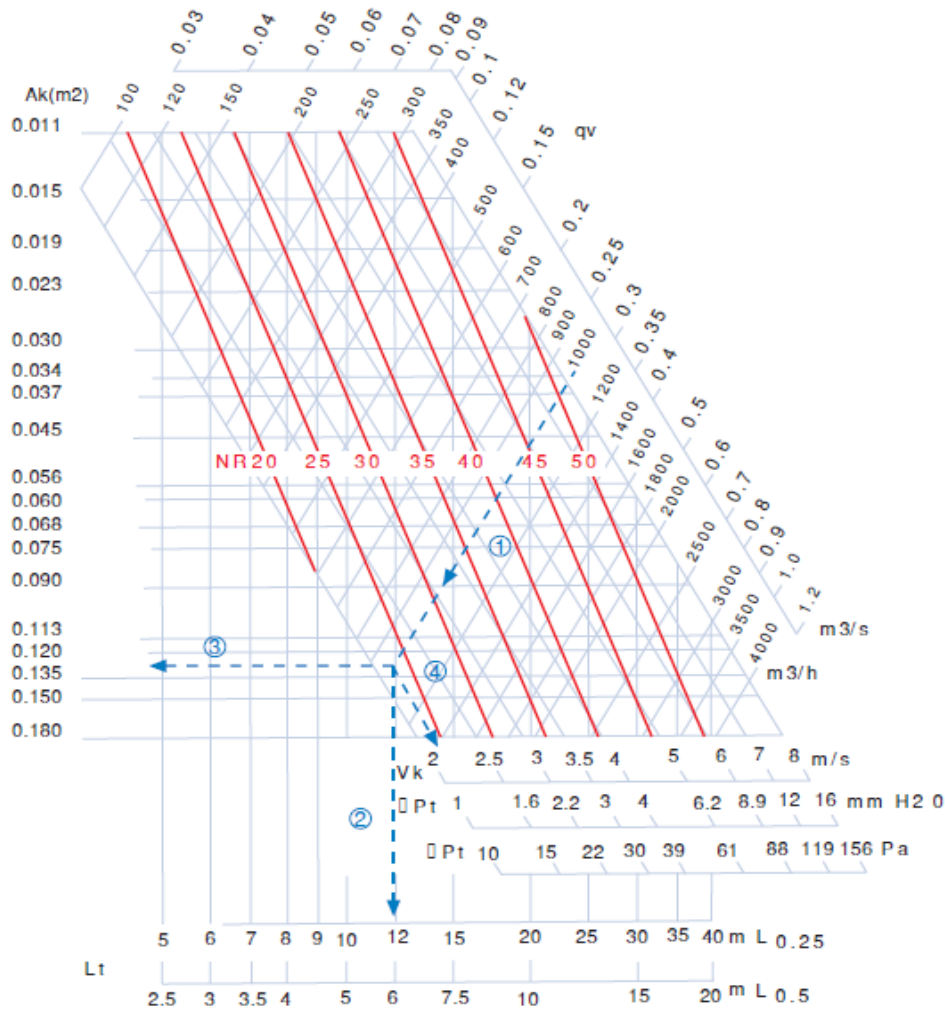

Diagram-1

Damper Position	Without Damper	%100 OPEN	%50 OPEN	%25 OPEN
Pt	Pt x 0,50	Pt x 1,00	Pt x 2,25	Pt x 5,90
Lw	Lw -4	Lw + 0	Lw +10	Lw +20

Table-3

SELECTION CRITERIA

Ceiling Height
H = 3+- 0,5 mm
Vt = 0,25 m/s
Damper %100 open

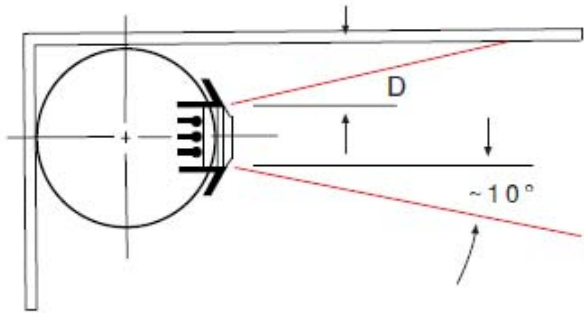

A) With Ceiling Effect
D= max.0,30m
(Selection Table)

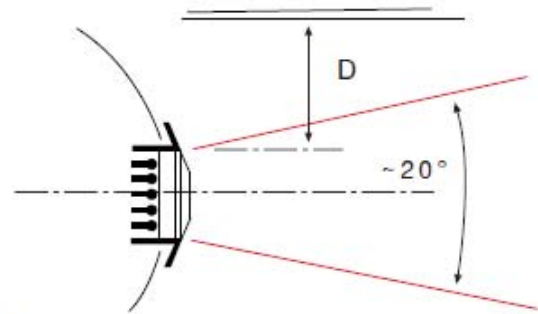

B) Without Ceiling Effect
D=max.0,90m
(Correction Chart)

	Lt	Vk	Pt	Lw
22°	x 0,77	x 1,15	x 1,30	+3
45°	x 0,55	x 1,25	x 1,60	+6

Table-4 Different Wing Angles for Correction Table

V _t (m/s)		0.25	0.375	0.5	0.625
L _t	A	x 1	x 0.67	x 0.5	x 0.4
	B	x 0.7	x 0.47	x 0.35	x 0.28

Table-5 V_t for Correction Table

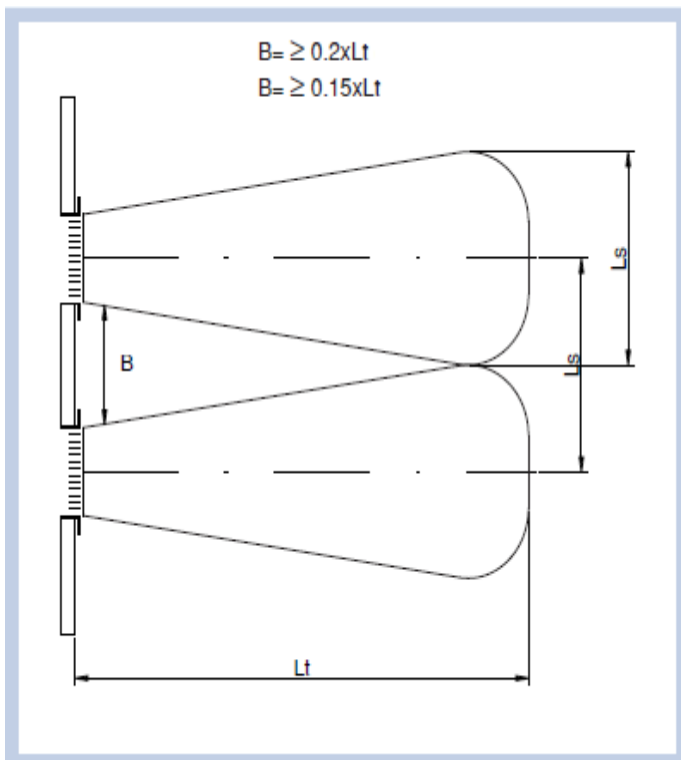

AIR FALL DIAGRAM:

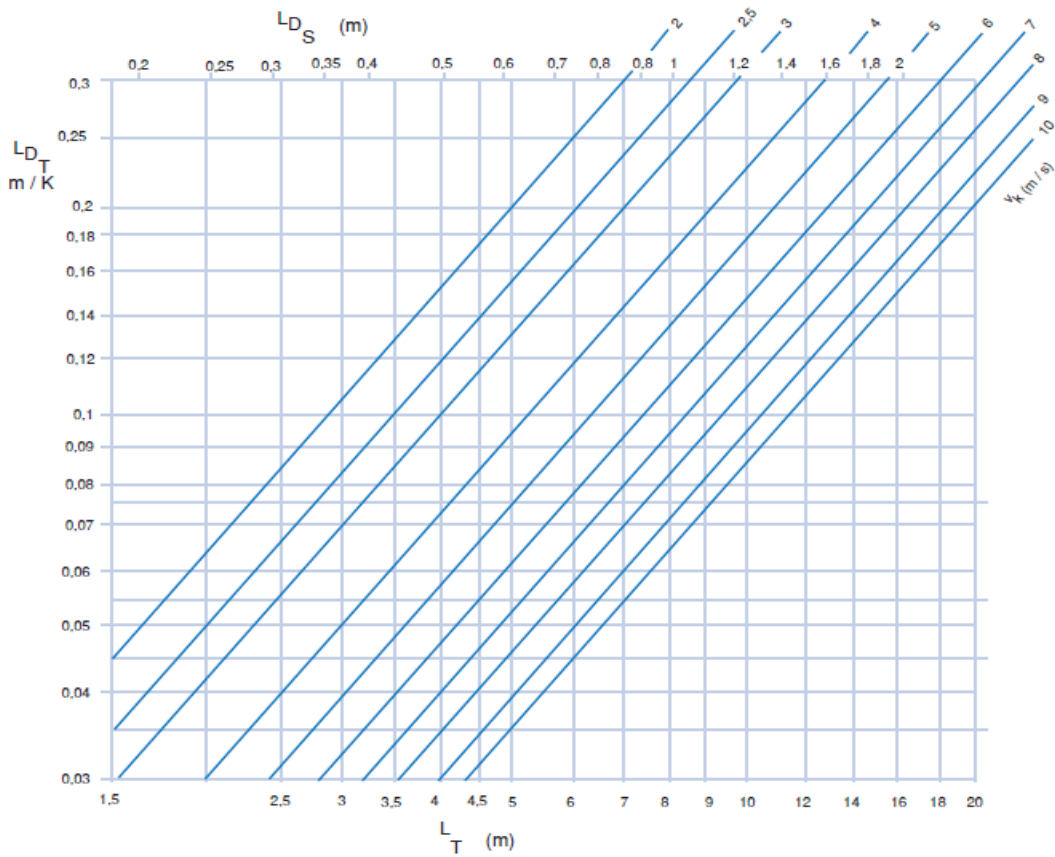
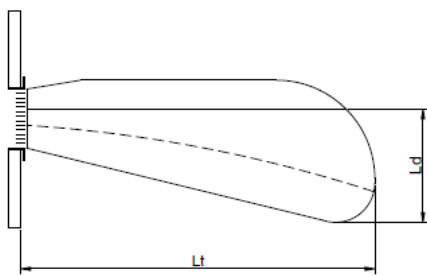

Diagram-2

AIR FALL



Description :

The total air drop is the vertical distance between the air drop center and the lowest point to the air drop V_t (m / s). Total air loss consists of two components.

$$L_d = L_{ds} + L_{dt}$$

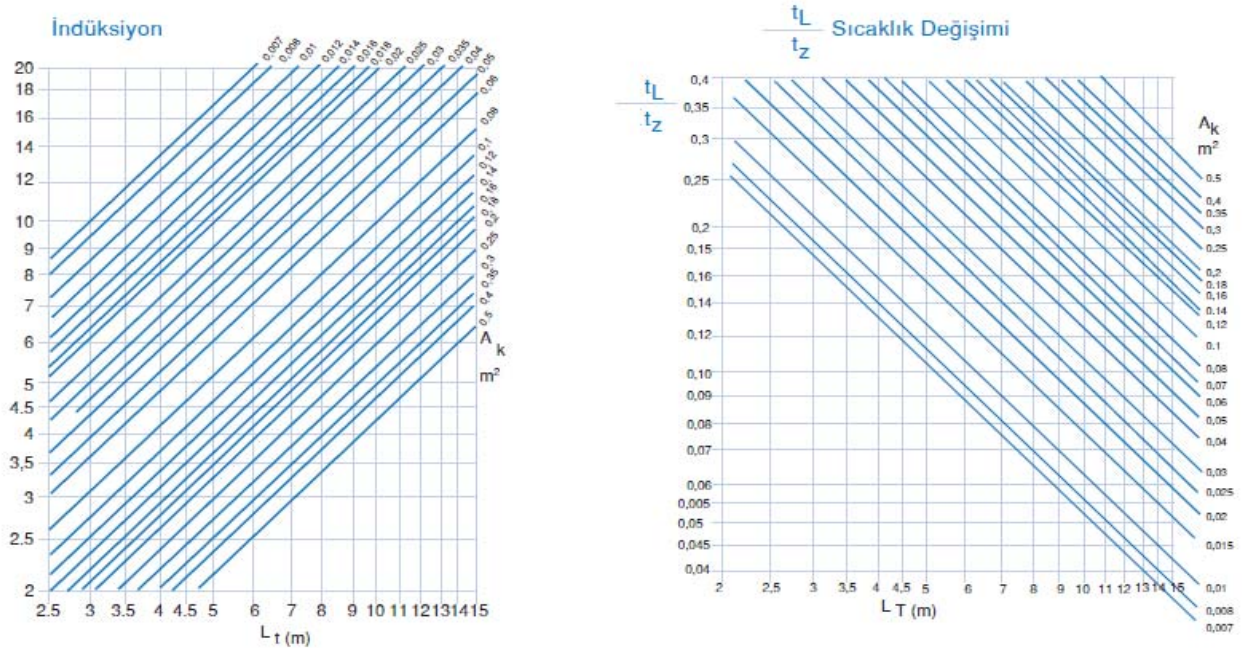

Diagram-3

T_L / T_Z : Temperature Change

T_L (K) : Maximum temperature difference between room temperature and air temperature

T_Z (K) : Maximum temperature difference between room temperature and distributor air temperature

l : induction

SAMPLE SELECTION

Data

$Q_v = 1.000 \text{ m}^3/\text{h}$ ①

Room Length = 12m ②

$V_t = 0.25 \text{ m/s}$

Result

$A_k = 0.125 \text{ m}^2$ ③

$V_k = 2.2 \text{ m/s}$ ④

$W \times H = 825 \times 225 \text{ mm}$

$p_t = 13 \text{ Pa}$

$L_t = 12 \text{ m}$



RETURN ROUND DUCT GRILLE:

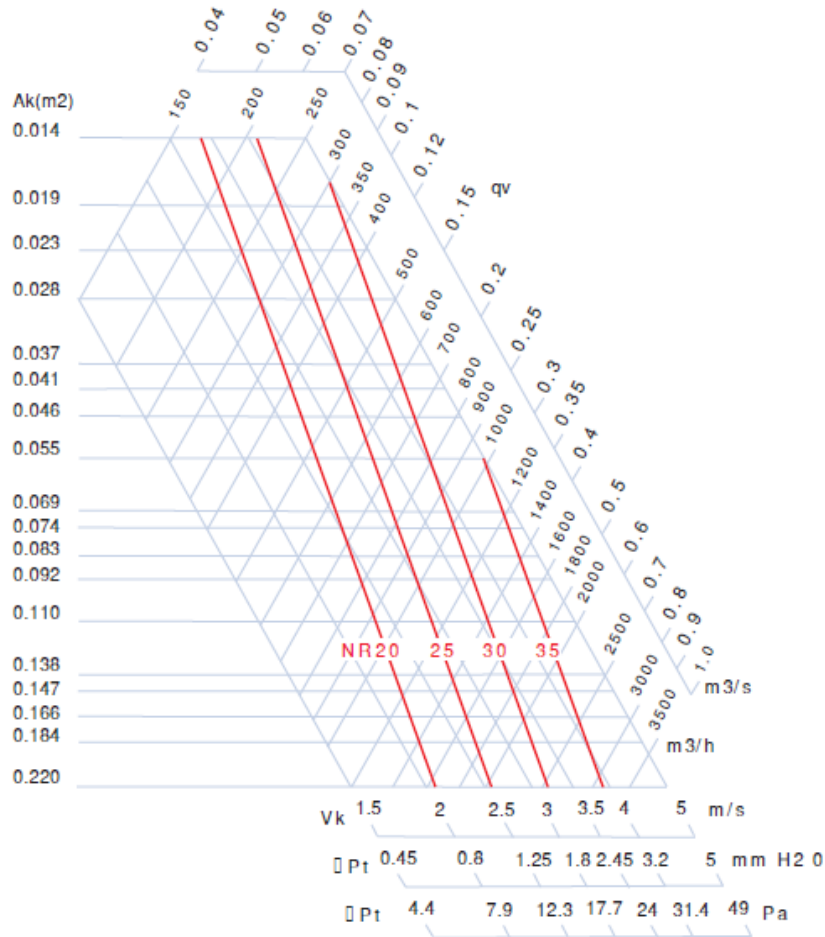

Diagram – 4

Damper Position	Without Damper	%100 OPEN	%50 OPEN	%25 OPEN
Pt	Pt x 0,50	Pt x 1,00	Pt x 2,25	Pt x 5,90
Lw	Lw -4	Lw + 0	Lw +10	Lw +20

Table-6

SELECTION CRITERIA

Ceiling Height
 $H = 3 \pm 0,5$ mm
 $V_t = 0,25$ m/s
 Damper %100 open

MOUNTING DETAILS

1. Screw Mounting Details

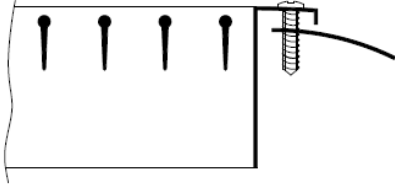



ORDER CODES

YKM - T	PKD	FB9010	VD	W 2000X100
<p>T : Return - SINGLE DEFLECTION GRILLES D : Supply - DOUBLE DEFLECTION GRILLES</p>				<p>W: Neck Size C: Frame Size</p>
<p>000: without Damper HKD: inclined Blade hit Damper PKD: Parallel Blade Damper</p>				<p>00: without Mounting VD: Screw Mounting</p>
				<p>00: without coating FB----: Powder Coated RAL</p>