



MODEL CAV

CONSTANT AIR VOLUME CONTROL DAMPER

Project:
Tag:
Engineer:
Contractor:
Date:

Prismatic Model
CAV-153

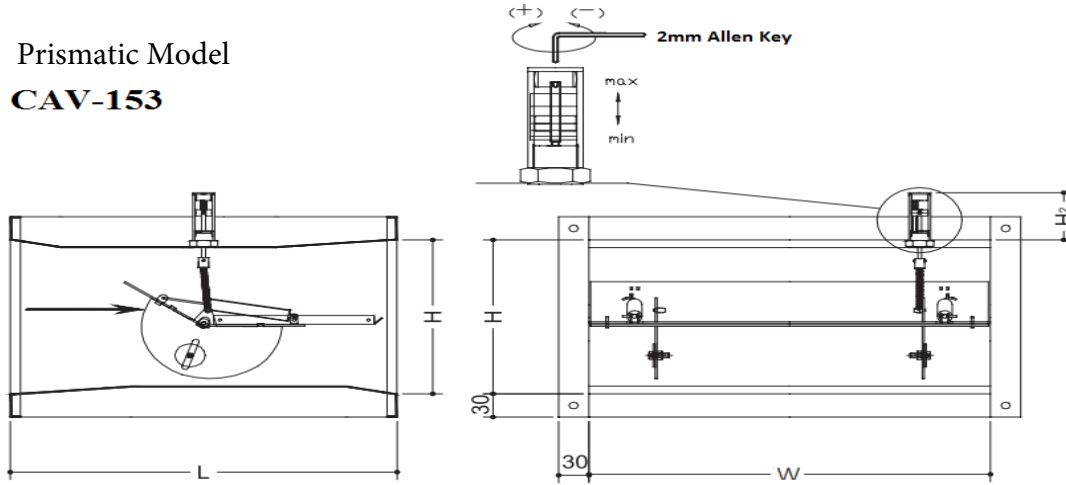

Length L [mm]	W [mm]										
	150	200	250	300	350	400	450	500	550	600	
H [mm]	100	220	220	220	-	-	-	-	-	-	-
	150	220	220	220	220	220	220	-	-	-	-
	200	220	220	220	220	220	220	385	385	385	385
	250	-	-	385	385	385	385	385	385	385	385
	300	-	-	-	385	385	385	385	385	385	385
	400	-	-	-	-	-	385	-	385	-	385
	500	-	-	-	-	-	-	-	425	-	425
600	-	-	-	-	-	-	-	-	-	470	

CAV-253

Circular model

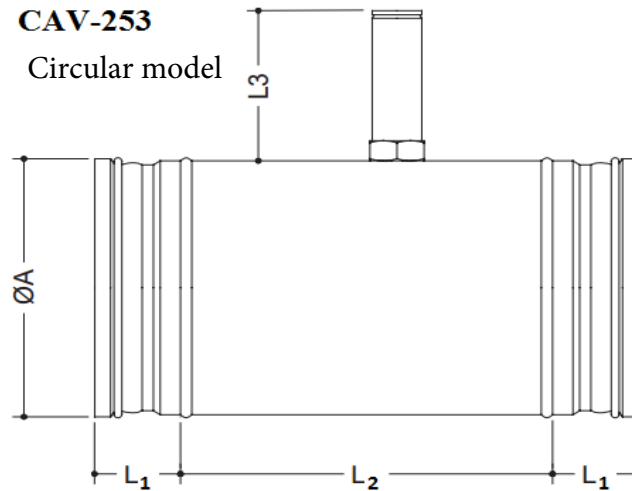

CAV-253 STANDARD SELECTION TABLE

ØN [mm]	80	100	125	160	200	250	315	400
ØA [mm]	78	98	123	158	198	248	313	398
L1 [mm]	40	40	40	40	40	40	60	60
L2 [mm]	120	170	170	240	240	240	220	295
L3 [mm]	70	70	70	70	70	70	100	100

As part of our continuous improvement program, we reserve the right to make further improvements without notice.

Date submitted: